





TFG Ingeniería Civil -PLANOS-

MEJORA Y ENSANCHE DE TRAMO ENTRE LOS PPKK 0+100 Y 0+480 EN NA-7063 (EGUILLOR – VALLE DE OLLO)

ÍNDICE DE PLANOS



00 DIDÁCTICO DE EJECUCIÓN	Pág. 1 y 2
00.2 UBICACIÓN EN MAPA DISTRITO	Pág. 3
01 PLANTA ACTUAL. (COMPLETA)	Pág. 4
02 PLANTA ACTUAL. (DETALLE; OESTE)	Pág. 5
03 PLANTA ACTUAL. (DETALLE; ESTE)	Pág. 6
04 SECCIÓN TIPO	Pág. 7
05 PLANTA MODIFICADA (COMPLETA)	Pág. 8
06 PLANTA MODIFICADA (DETALLE; OESTE)	Pág. 9
07 PLANTA MODIFICADA (DETALLE; ESTE)	Pág. 10
08 LONGITUDINAL	Pág. 11
09 TRANSVERSALES	Pág. 12 a 15
10 PLANTA EXPROPIACIONES (OCUPACIONES)	Pág. 16
11 DETALLES CONSTRUCTIVOS	Pág. 17
12 SEÑALIZACIÓN DE OBRA	Pág. 18





-  MBC (8 cm)
-  ZAHORRA (22 cm)
-  BASE (30 cm)

MACADAM 

BASE 

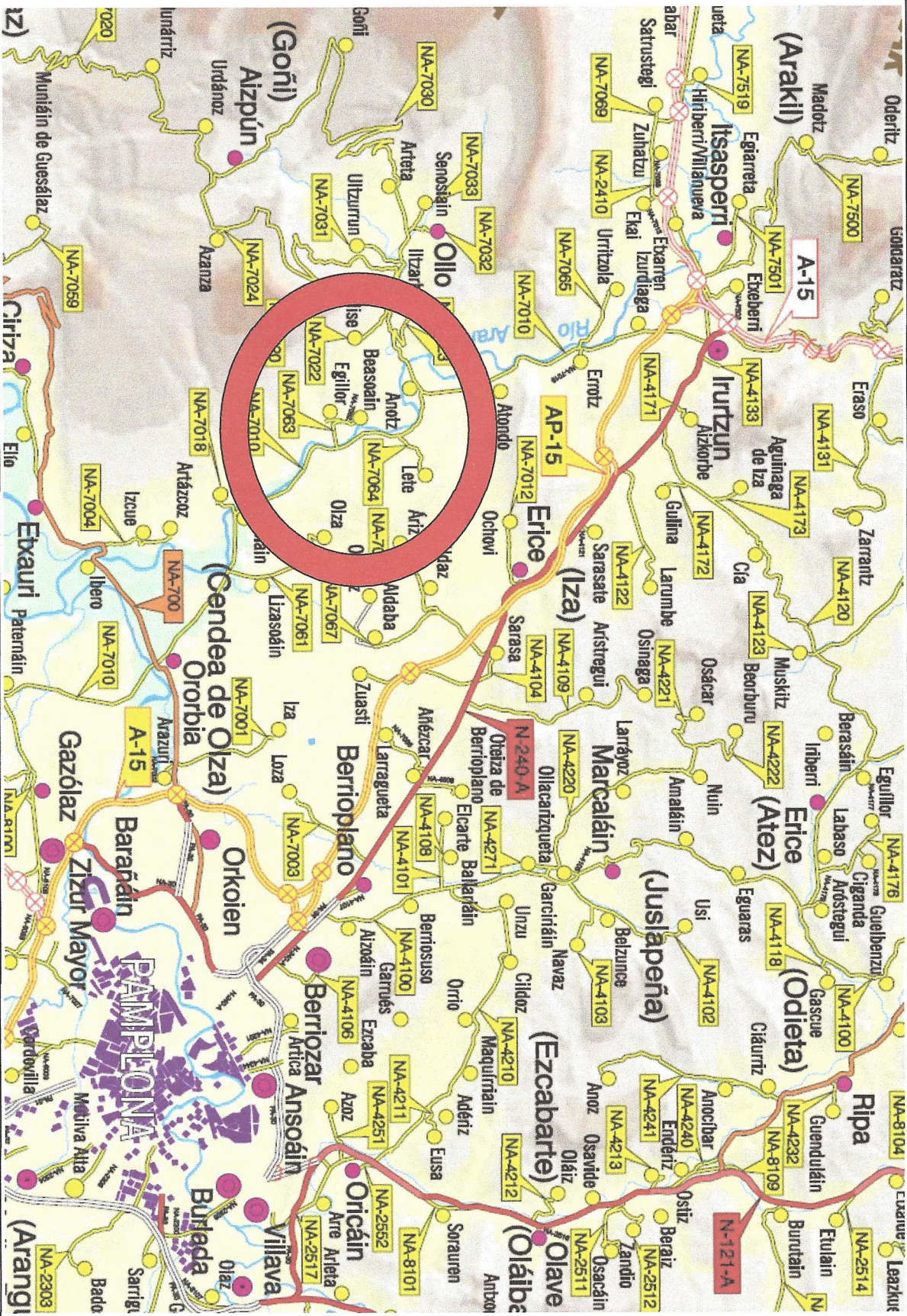
 	AUTOR DEL PROYECTO: ECHEGARAY ESCRURRA, INIGO 	
	NOMBRE DEL PROYECTO: MEJORA Y ENSANCHE DE TRAMO ENTRE LOS PPK 0+100 Y 0+480 EN NA-7063 (EGUILLOR - VALLE DE OLLIO)	
DESIGNACIÓN DEL PLANO DIDÁCTICO DE EJECUCIÓN		ESC.: A-4 S/S
PLANO 00/12		DATA: 21-11-14 HOJA 1 DE 02



<p>AUTOR DEL PROYECTO: EHEGARRAK EZCURRA, INGENIO</p> 	<p>NOMBRE DEL PROYECTO: MEJORA Y ENSANCHE DE TRAMO ENTRE LOS PKK 0+100 Y 0+480 EN NA-7063 (EGUILLOR - VALLE DE OLLIO)</p>	<p>DESIGNACIÓN DEL PLANO UBICACIÓN EN DISTRITO</p>	<p>ESC.: A-4 1/150.000</p>	<p>PLANO 0/12</p>
	<p>DATA: 21-11-14</p>	<p>HOJA 3 DE 03</p>		



		<p>AUTOR DEL PROYECTO: ECHEGARAY EZCURRA, INIGO</p>	<p>NOMBRE DEL PROYECTO: MEJORA Y ENSANCHE DE TRAMO ENTRE LOS PPKK 0+100 Y 0+480 EN NA-7063 (EGUILLOR - VALLE DE OLLIO)</p>	<p>DESIGNACIÓN DEL PLANO PLANTA ACTUAL (COMPLETA)</p>	<p>ESC.: A-4 GRÁFICA</p>	<p>PLANO 1/12 HOJA 1 DE 01</p>
<p>ESCALA GRÁFICA 0 25 50 M</p>		<p>DATA: 21-11-14</p>				

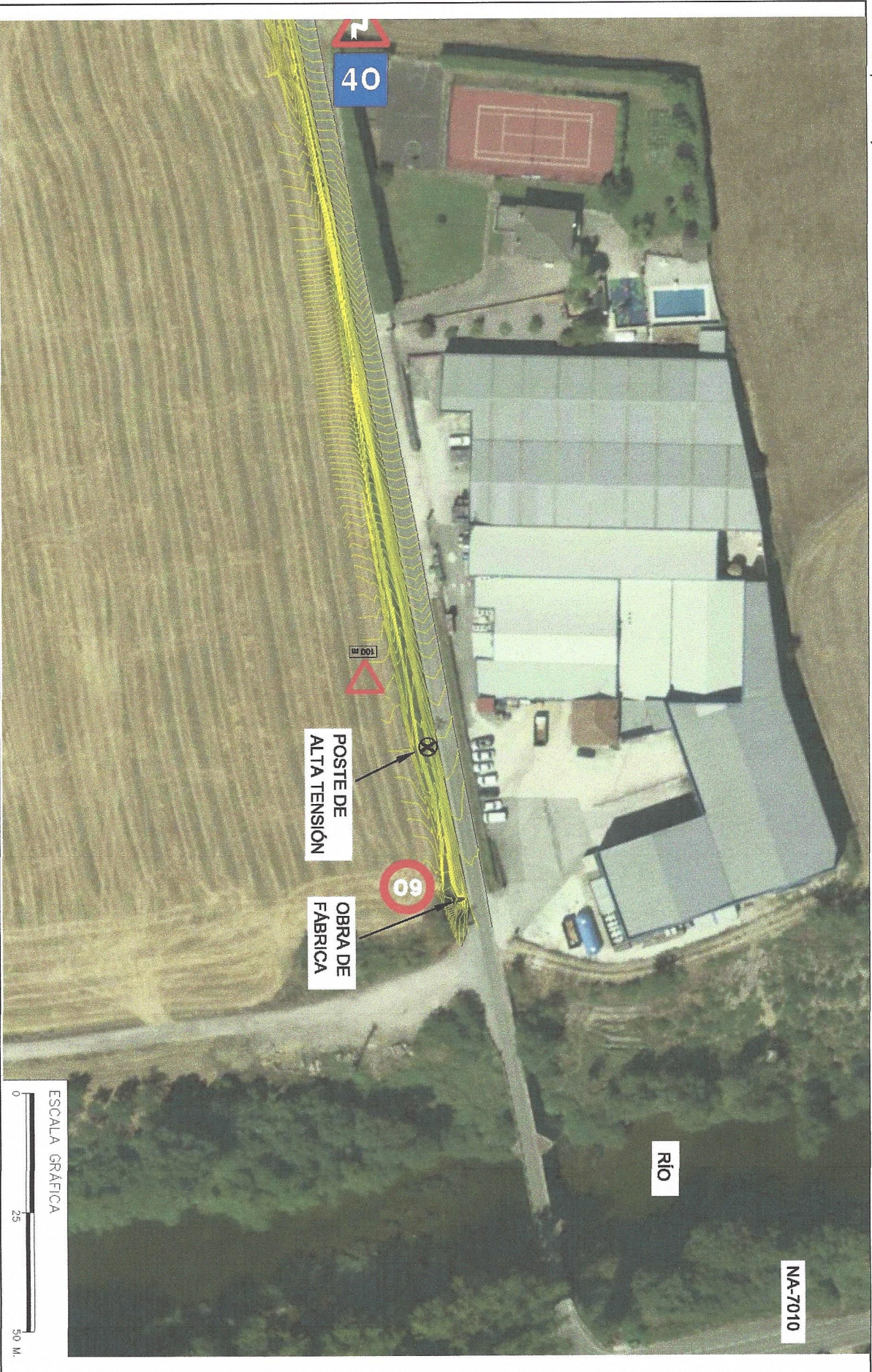

ESCALA GRÁFICA
0 25 50 M.

	<p>AUTOR DEL PROYECTO: EHEGAMAY EZCURRA, INGENIO</p> 	<p>NOMBRE DEL PROYECTO: MEJORA Y ENSANCHE DE TRAMO ENTRE LOS PPKK 0+100 Y 0+480 EN NA-7063 (EGULLIOR - VALLE DE OLLIO)</p>	<p>DESIGNACIÓN DEL PLANO PLANTA ACTUAL (DETALLE: OESTE)</p>	<p>ESC.: A-4 GRÁFICA</p> <p>DATA: 21-1-14</p>	<p>PLANO 2/12 HOJA 1 DE 01</p>
---	--	---	--	---	--

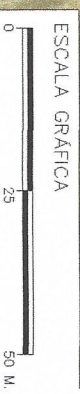
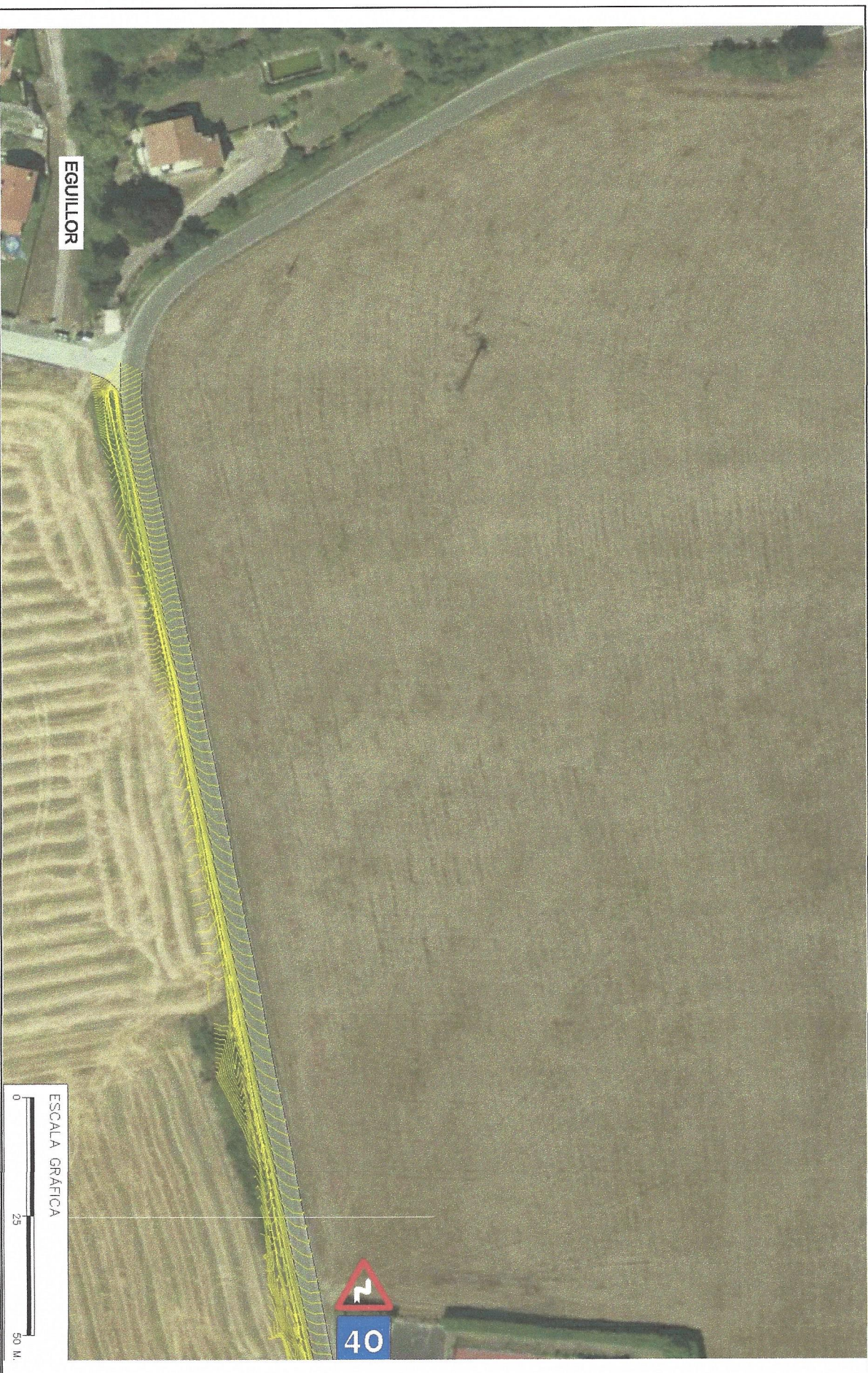

	AUTOR DEL PROYECTO: ECHEGARAY-EZQUERRA, INIGO	NOMBRE DEL PROYECTO: MEJORA Y ENSANCHE DE TRAMO ENTRE LOS PPKK 0+100 Y 0+480 EN NA-7063 (EGULLOR - VALLE DE OLLIO)	DESIGNACIÓN DEL PLANO PLANTA ACTUAL (DETALLE: ESTE)	ESC.: A-4 GRÁFICA DATA: 21-11-14	PLANO 3/12 HOJA 1 DE 01
--	--	--	--	---	--

Detalle sección tipo ensanche

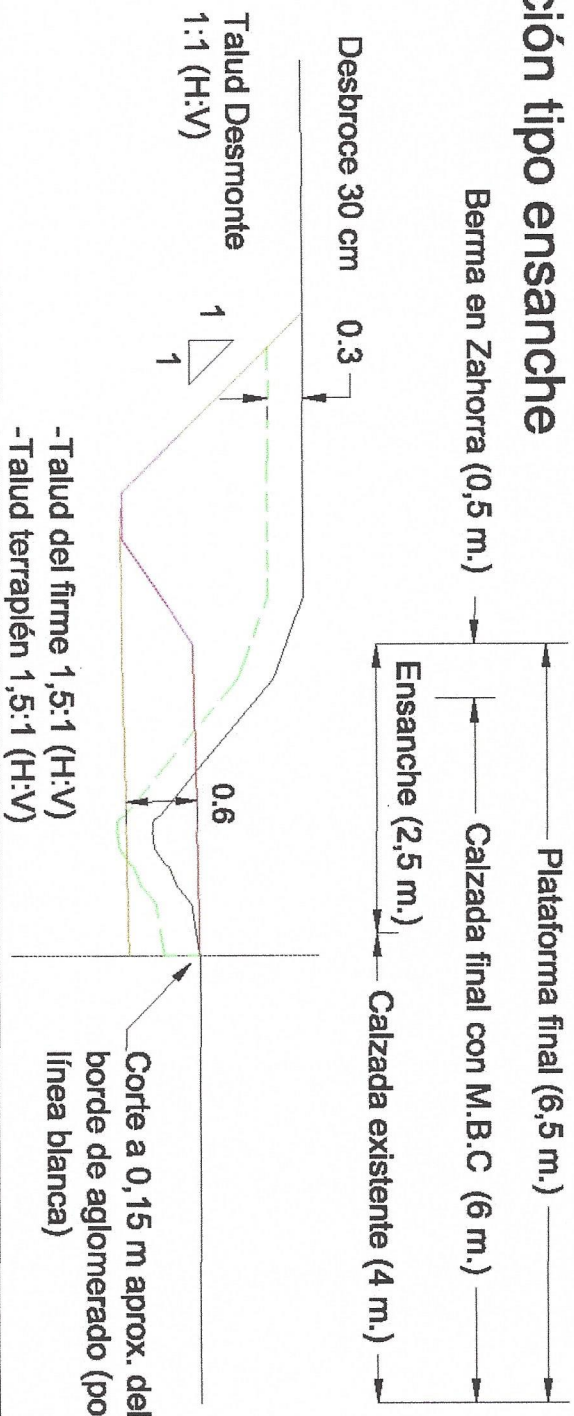

Detalle firme

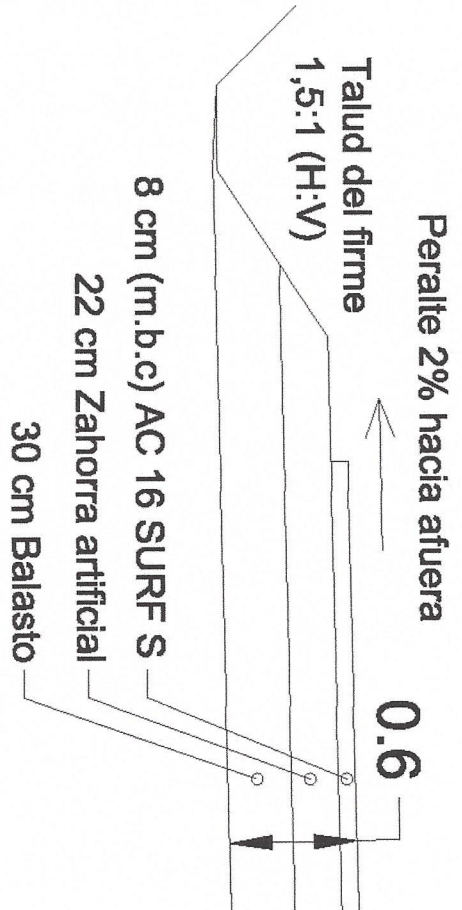

Detalle cuneta en tierras

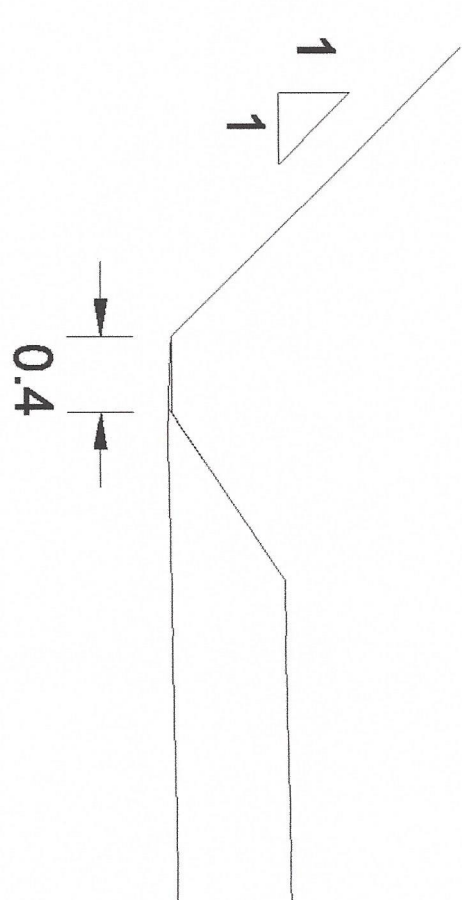

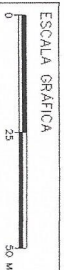
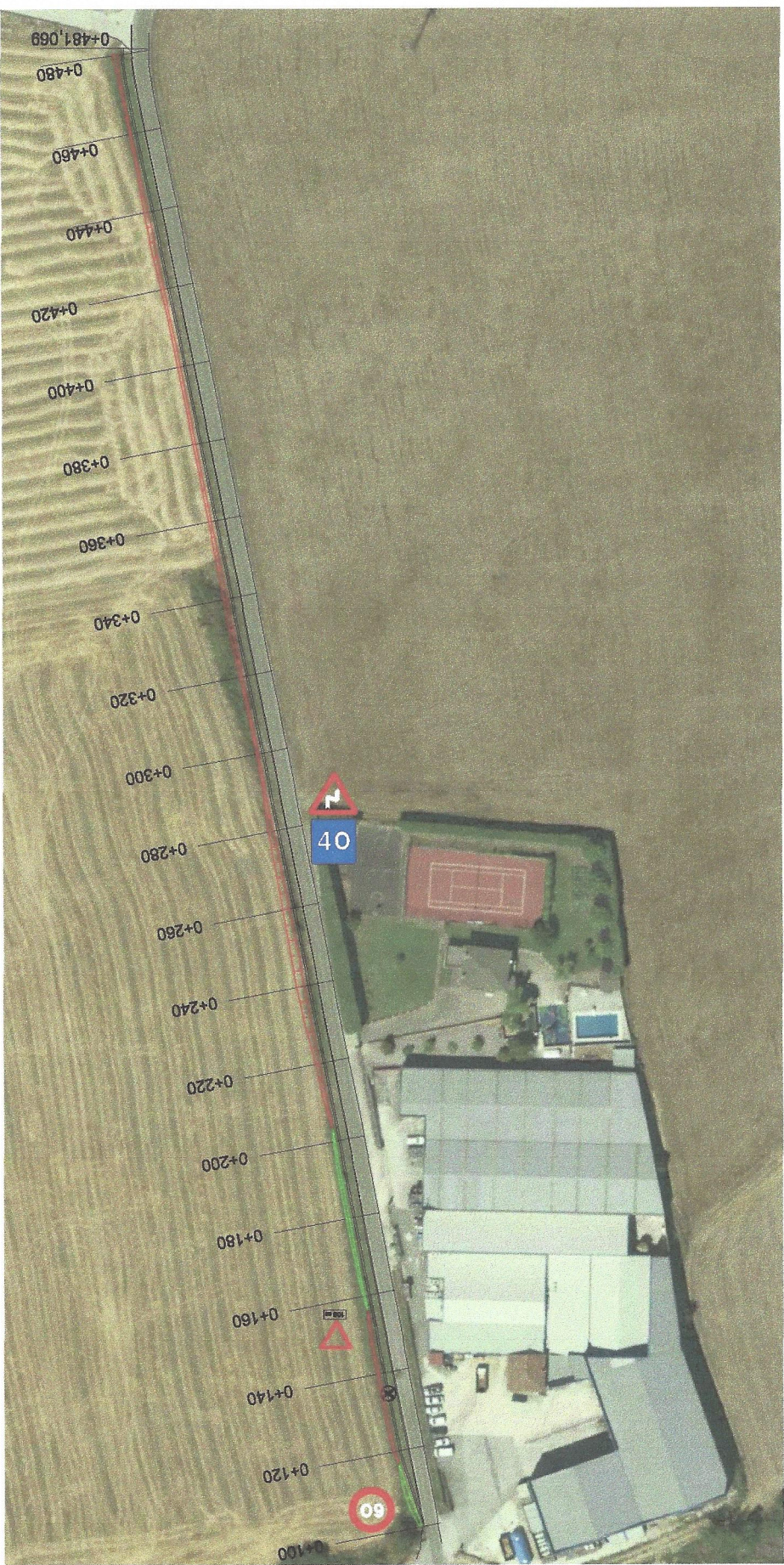

		AUTOR DEL PROYECTO: ECHEGARAY EZCURRA, INGGO	NOMBRE DEL PROYECTO:: MEJORA Y ENSANCHE DE TRAMO ENTRE LOS PPKK 0+100 Y 0+480 EN NA-7063 (EGULLOR - VALLE DE OLLIO)	DESIGNACIÓN DEL PLANO SECCIÓN TIPO	ESC.: A-4 VARIAS (ACOTADO)	PLANO 4/12 HOJA 1 DE 01
--	--	---	---	--	----------------------------------	----------------------------

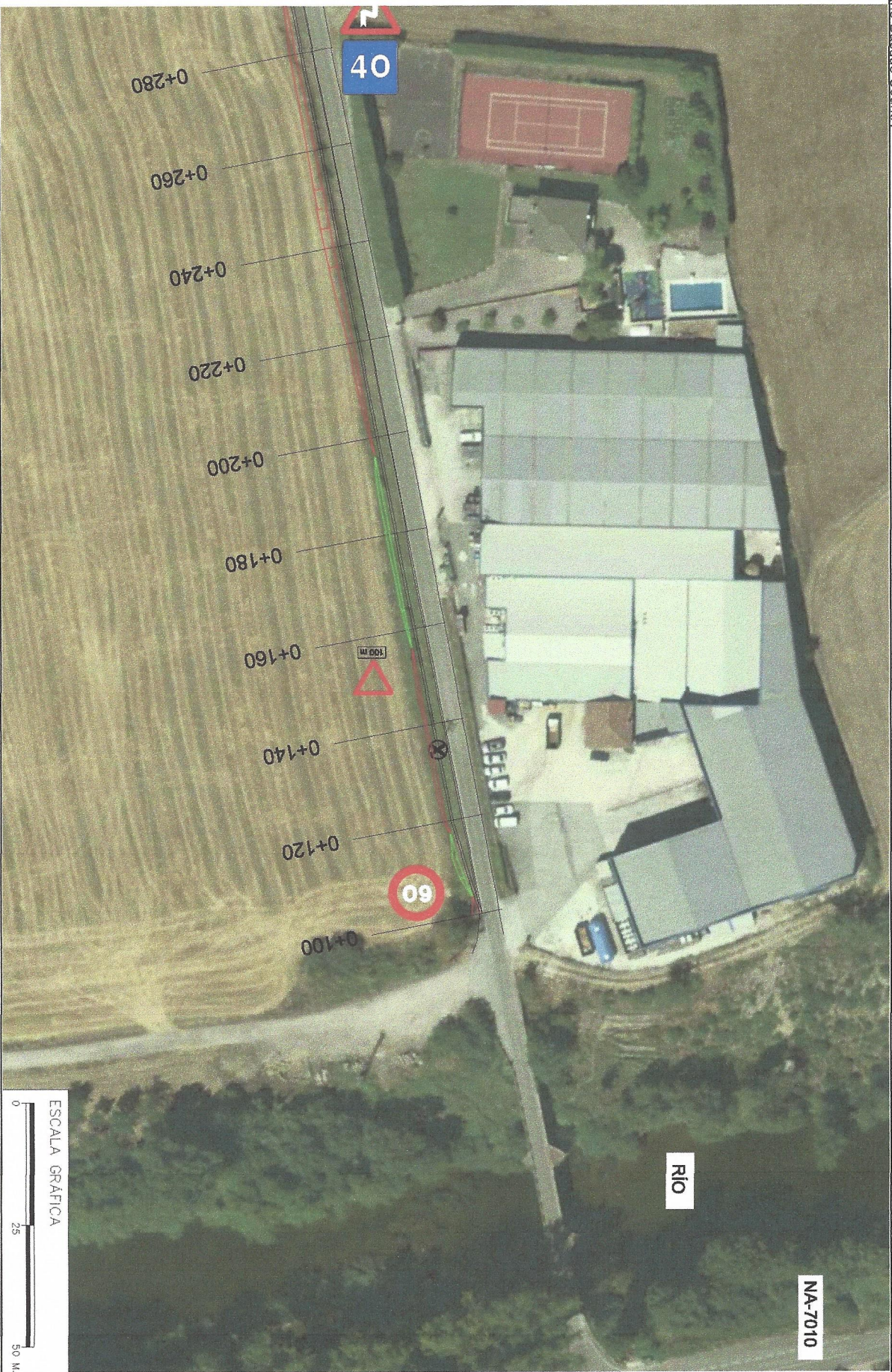

		AUTOR DEL PROYECTO: ECHEGARAY ESCRIBANA, INIGO	
		NOMBRE DEL PROYECTO: MEJORA Y ENSANCHE DE TRAMO ENTRE LOS PKK 0+100 Y 0+480 EN NA-7063 (EGUILLOR - VALLE DE OLLIO)	
DESIGNACIÓN DEL PLANO (COMPLETA)		PLANTA MODIFICADA (COMPLETA)	
ESC.: A-4 GRÁFICA	PLANO 5/12	DATA: 21-11-14	HOJA 1 DE 01



 		AUTOR DEL PROYECTO: ECHEGARAY EZCURRA, INIGO		NOMBRE DEL PROYECTO: MEJORA Y ENSANCHE DE TRAMO ENTRE LOS PPKK 0+100 Y 0+480 EN NA-7063 (EGULLIOR - VALLE DE OLLIO)		DESIGNACIÓN DEL PLANO PLANTA MODIFICADA (DETALLE; OESTE)		ESCALA GRÁFICA 0 25 50 M.	
								ESC.: A-4 GRÁFICA	
								PLANO 6/12	
								HOJA 1 DE 01	
								DATA: 21-11-14	

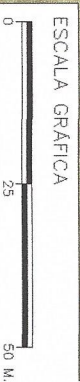
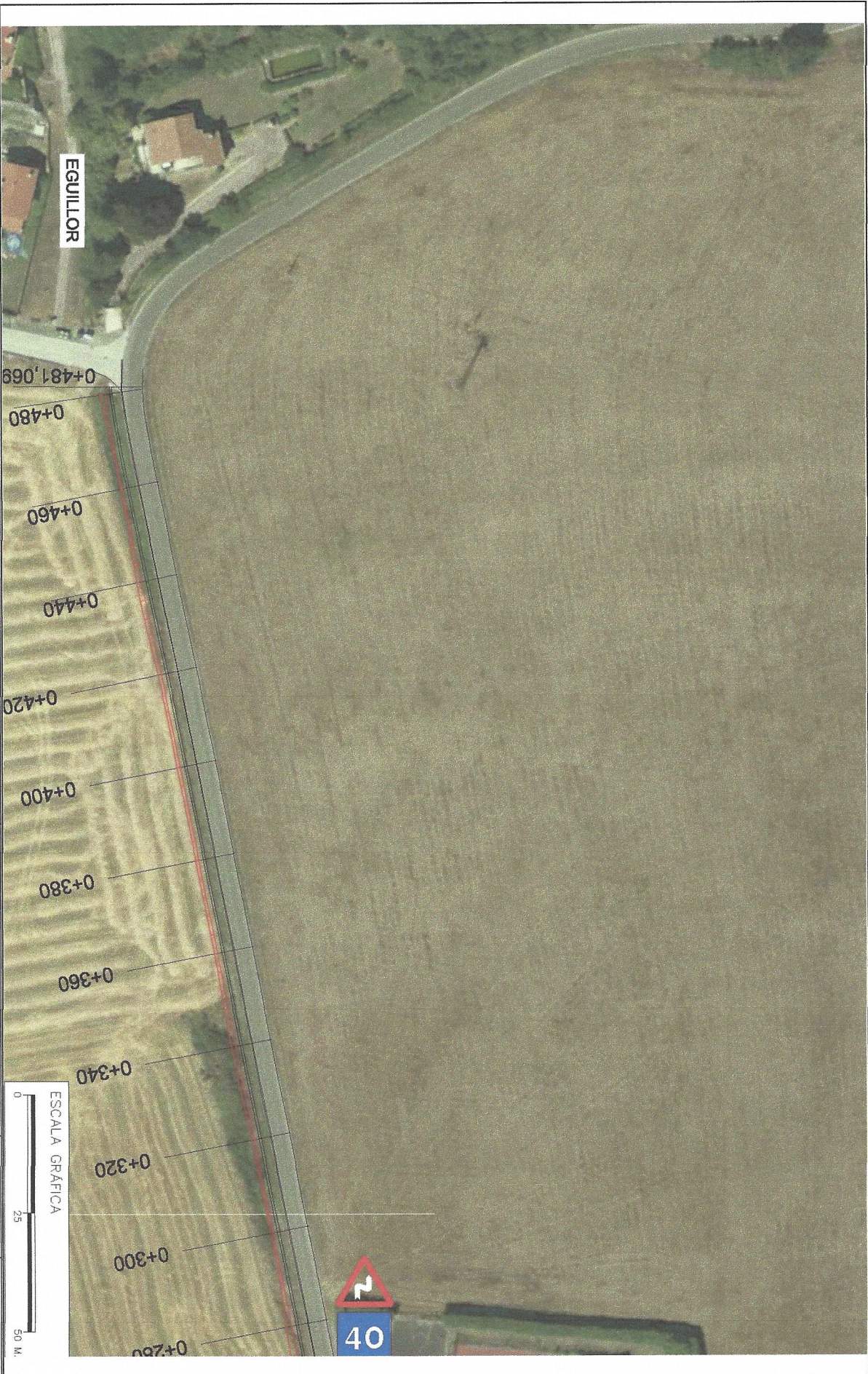

		AUTOR DEL PROYECTO: ECHEGARAY EZCURRA, INIGO	NOMBRE DEL PROYECTO:: MEJORA Y ENSANCHE DE TRAMO ENTRE LOS PPKK 0+100 Y 0+480 EN NA-7063 (EGULLOR - VALLE DE OLLIO)	DESIGNACIÓN DEL PLANO PLATA MODIFICADA (DETALLE: ESTE)	ESC: A-4 GRÁFICA	PLANO 7/12
					DATA: 21-11-14	HOJA 1 DE 01

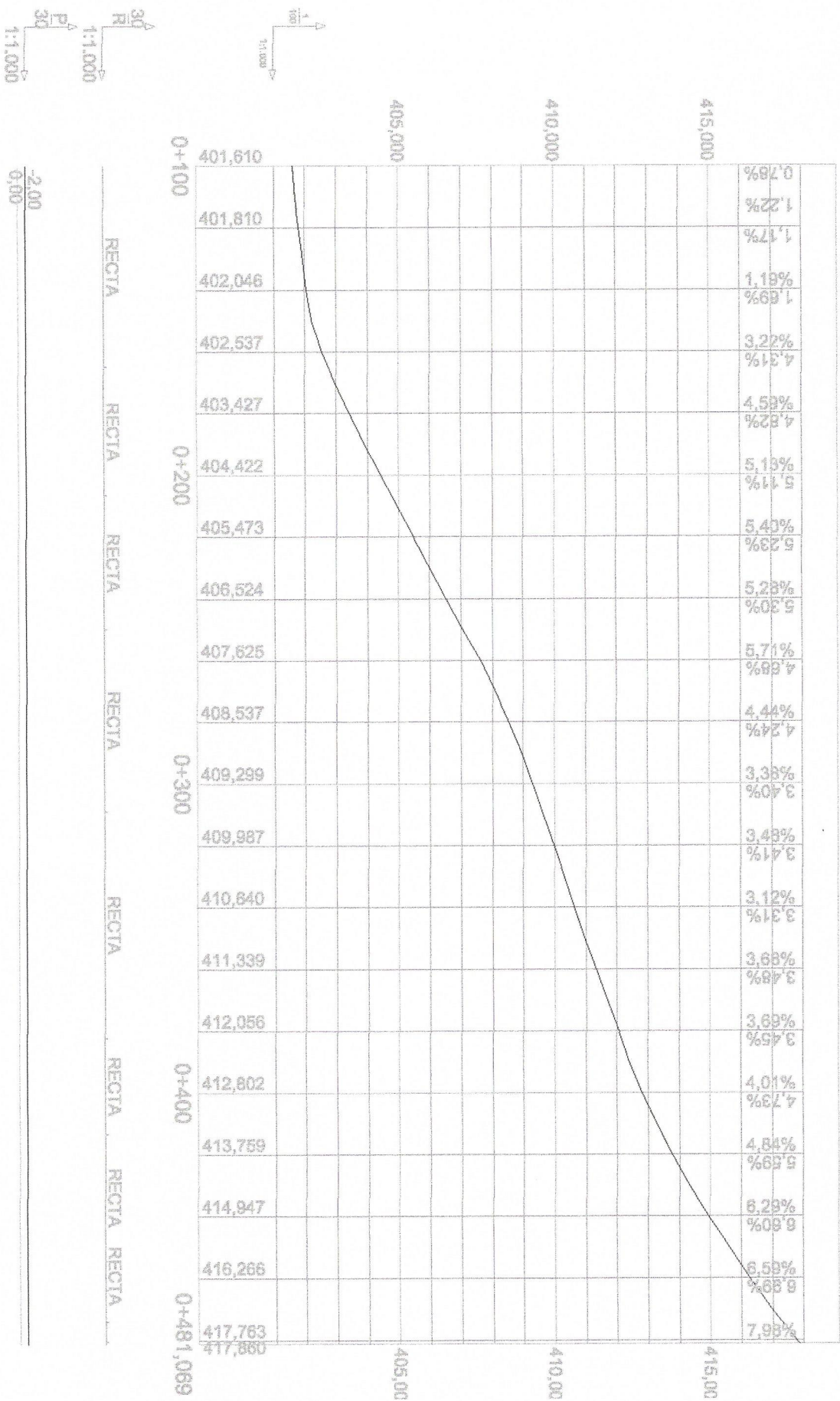

AUTOR DEL PROYECTO:
EHEGARAY-EZCERRA,
INIGO

NOMBRE DEL PROYECTO:
MEJORA Y ENSANCHE DE TRAMO ENTRE LOS
PPKK 0+100 Y 0+480 EN NA-7063 (EGULLOR -
VALLE DE OLLIO)



DESIGNACIÓN DEL PLANO
PERFIL LONGITUDINAL

ESC.: A-4
VARIAS
(REPRESENTADAS)

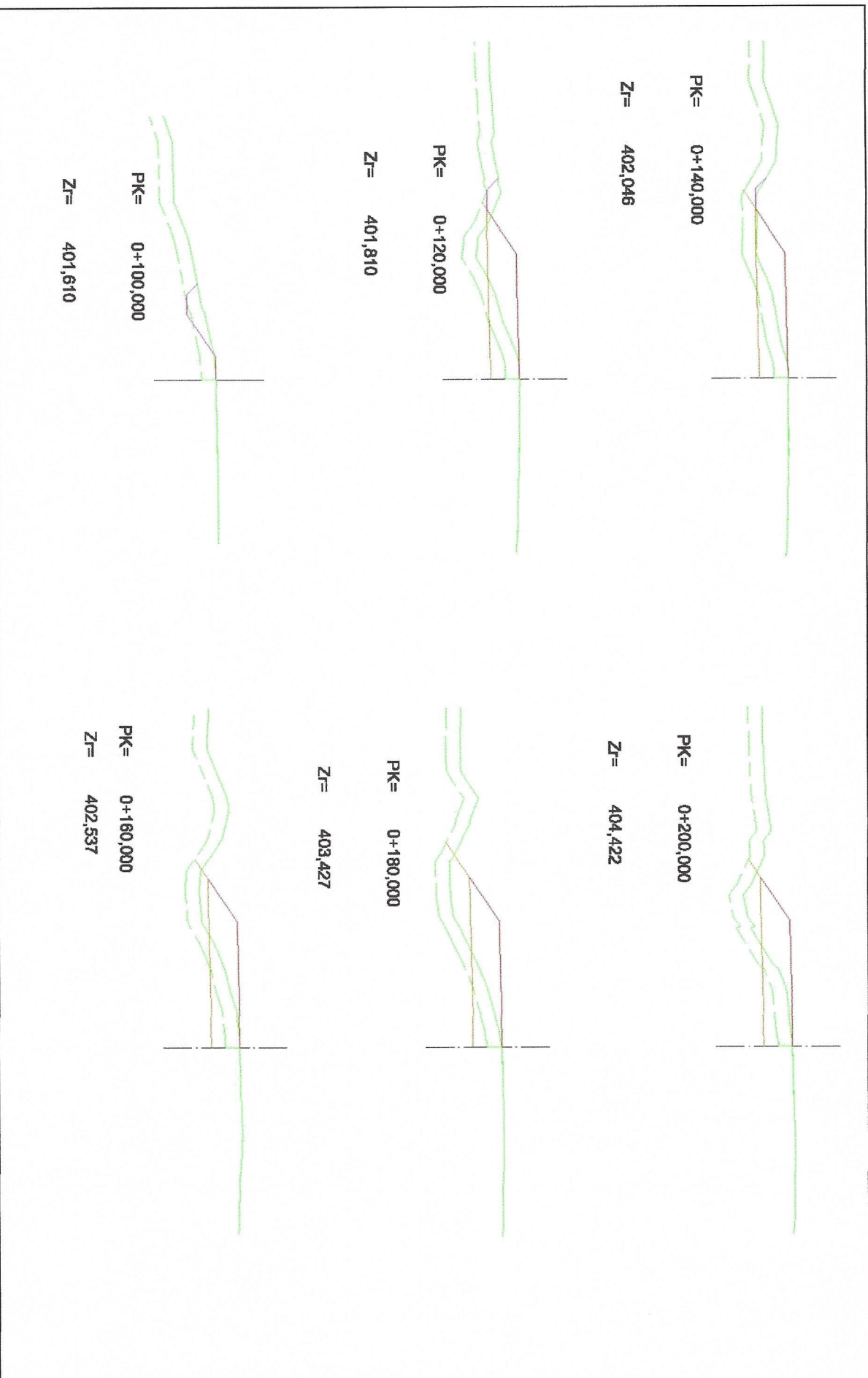

PLANO 8/12
HOJA 1 DE 01

DATA: 21-11-14



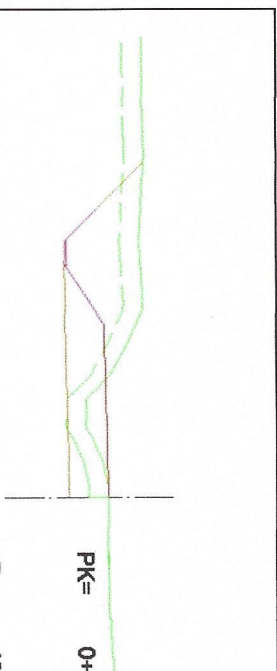
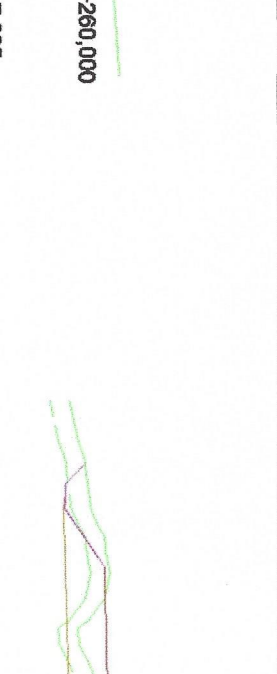
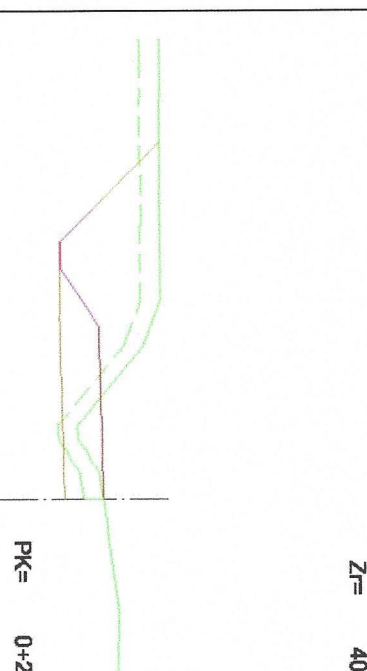
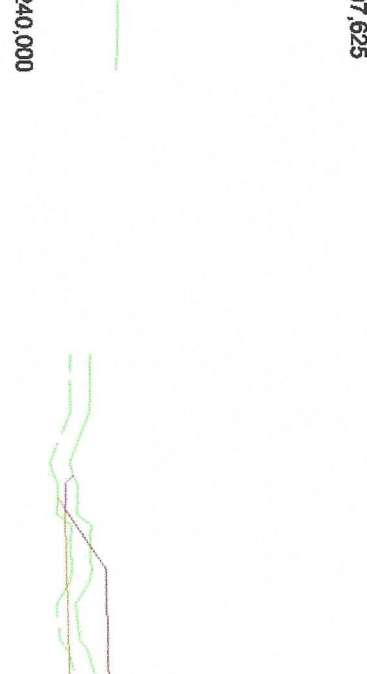
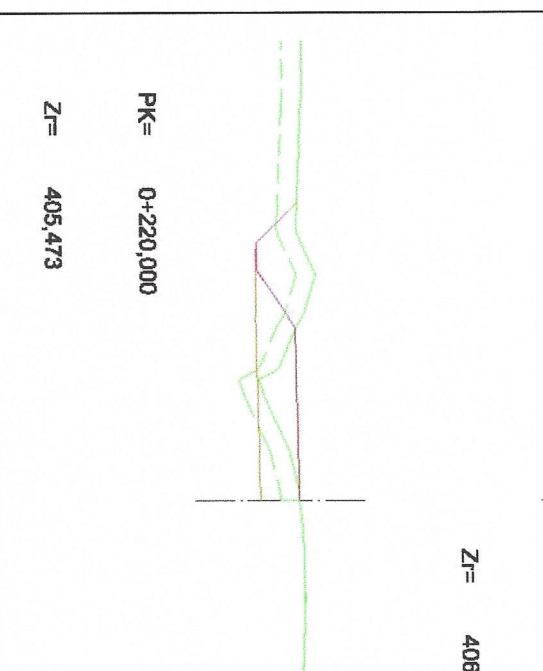

	AUTOR DEL PROYECTO: ECHEGAMATY EZQUERRA, INIGO		NOMBRE DEL PROYECTO: MEJORA Y ENSANCHE DE TRAMO ENTRE LOS PPKK 0+100 Y 0+480 EN NA-7063 (EGULLOR - VALLE DE OLLOR)		DESIGNACIÓN DEL PLANO PERFILES TRANSVERSALES	ESC.: A-4 1/100	PLANO 9/12
							

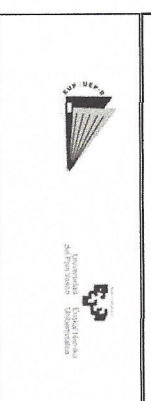

 <p>PK= 0+260,000 Zr= 407,625</p>	 <p>PK= 0+320,000 Zr= 409,987</p>
 <p>PK= 0+240,000 Zr= 406,524</p>	 <p>PK= 0+300,000 Zr= 409,299</p>
 <p>PK= 0+220,000 Zr= 405,473</p>	 <p>PK= 0+280,000 Zr= 408,537</p>

	<p>AUTOR DEL PROYECTO: ECHEGARAY EZCURRA, INGO</p> 	<p>NOMBRE DEL PROYECTO: MEJORA Y ENSANCHE DE TRAMO ENTRE LOS PPKK 0+100 Y 0+480 EN NA-7063 (EGULLOR - VALLE DE OLLIO)</p>	<p>DESIGNACIÓN DEL PLANO PERFILES TRANSVERSALES (2)</p>	<p>ESC: A-4 1/100 DATA: 21-11-14</p>	<p>PLANO 9/12 HOJA 2 DE 04</p>
--	---	---	---	--	------------------------------------

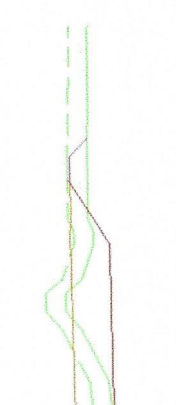
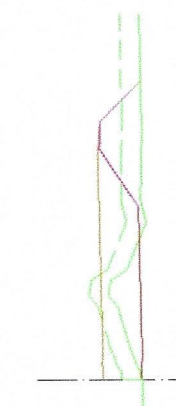
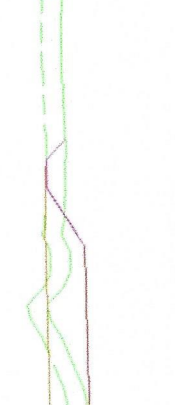
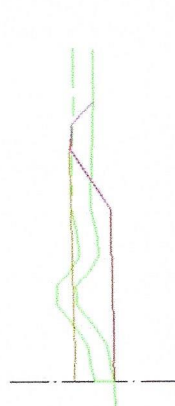
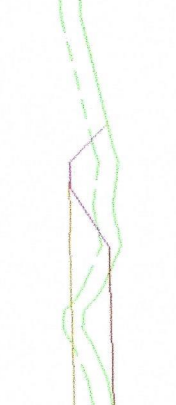
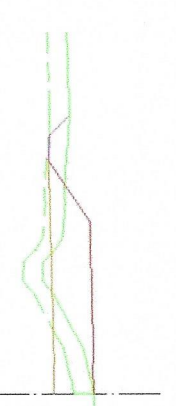



 <p>PK= 0+380,000 Zr= 412,056</p>	 <p>PK= 0+440,000 Zr= 414,947</p>		
 <p>PK= 0+380,000 Zr= 411,339</p>	 <p>PK= 0+420,000 Zr= 413,759</p>		
 <p>PK= 0+340,000 Zr= 410,640</p>	 <p>PK= 0+400,000 Zr= 412,802</p>		
 <p>UNIVERSIDAD DEL PAÍS VASCO EUSKAL HERRIKO UNIBERTSITATEA</p>	<p>AUTOR DEL PROYECTO: EHEGARAY EZCURRA, INGENIERO</p> <p>NOMBRE DEL PROYECTO: MEJORA Y ENSANCHE DE TRAMO ENTRE LOS PPKK 0+100 Y 0+480 EN NA-7063 (EGULLIOR - VALLE DE OLLIO)</p>	<p>DESIGNACIÓN DEL PLANO PERFILES TRANSVERSALES (3)</p> <p>ESC.: A-4 1/100</p> <p>DATA: 21-11-14</p>	<p>PLANO 9/12 HOJA 3 DE 04</p>



AUTOR DEL PROYECTO: ECHEGARAY-EZCURRA, INGO	NOMBRE DEL PROYECTO: MEJORA Y ENSANCHE DE TRAMO ENTRE LOS PPKK 0+100 Y 0+480 EN NA-7063 (EGUILLOR - VALLE DE OLLIO)	
DESIGNACIÓN DEL PLANO PERFILES TRANSVERSALES (4)	ESC: A-4 1/100	PLANO 9/12
	DATA: 21-11-14	HOJA 4 DE 04

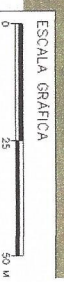
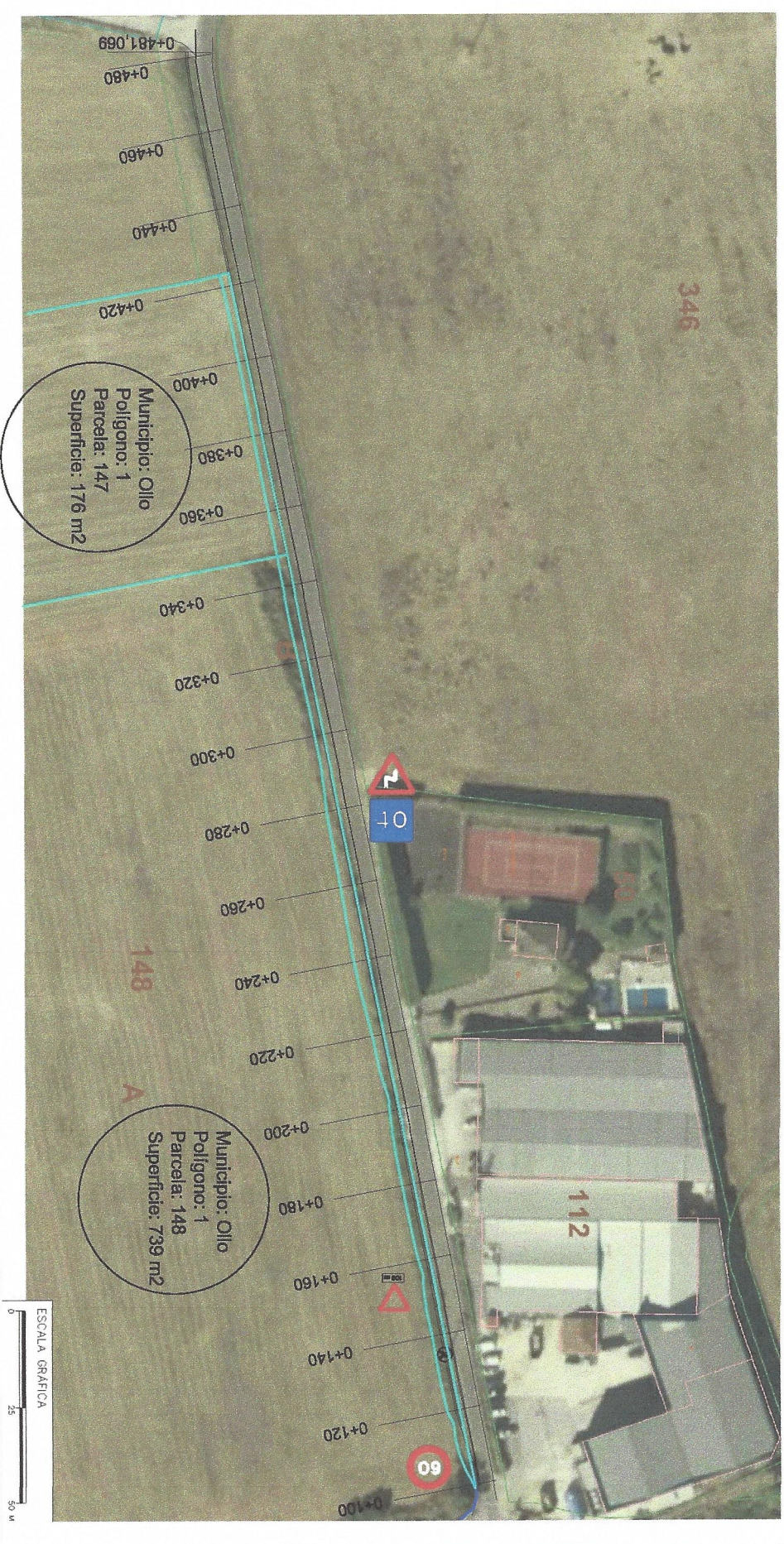



		<p>AUTOR DEL PROYECTO: ECHEGARAY-EZCURRA, INGO</p> 	<p>NOMBRE DEL PROYECTO: MEJORA Y ENSANCHE DE TRAMO ENTRE LOS PPKK 0+100 Y 0+480 EN NA-7063 (EGULLIOR - VALLE DE OLLIO)</p>	<p>DESIGNACION DEL PLANO PLANTA EXPROPIACIONES (OCUPACIONES)</p>	<p>ESC: A-4 GRÁFICA</p>	<p>PLANO 10/12</p>
<p>DATA: 21-1-14</p>	<p>HOJA 1 DE 01</p>					

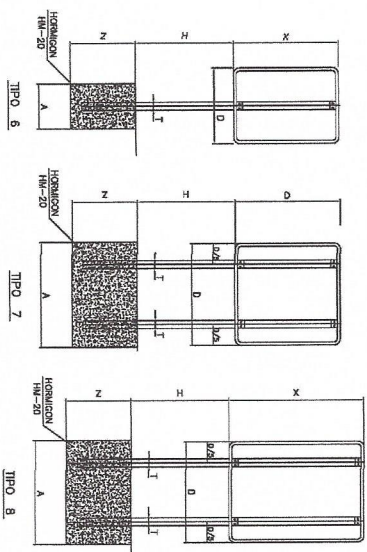
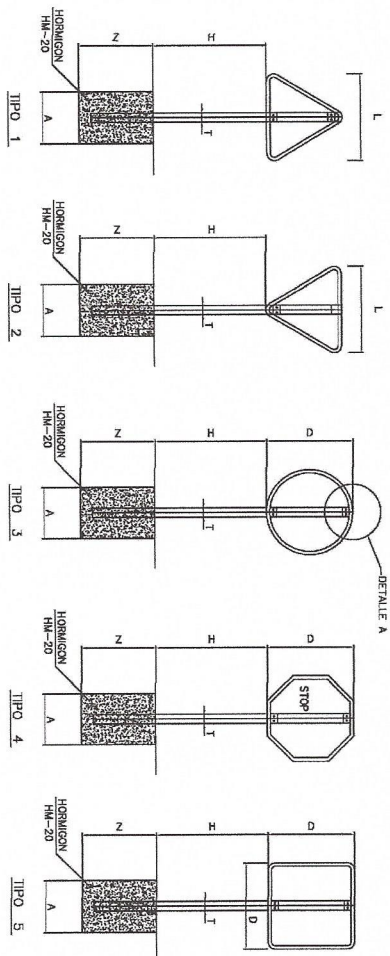

TIPO DE SEÑAL	TAMAJO DE LAS SEÑALES					
	1 Y 2	3	4	5 Y 7	6 Y 8	
SERIE A AUTOSTRA VA, AUTOSTRA VA, AUTOSTRA VA	175	120	120	150	150	
SERIE B CONVENCIONAL CON ARCENES	135	80	80	80	80	
SERIE C CONVENCIONAL CON ARCENES	90	90	80	80	80	
CLASE DE CARRETERA						
1	2	3	4	5	6	

SERIE	SERIE A						SERIE B						SERIE C					
	1	3	4	5	8	7	1	2	3	4	5	8	1	2	3	4	5	8
SEÑAL TIPO	1	3	4	5	8	7	1	2	3	4	5	8	1	2	3	4	5	8
ALTIMETRO-Hm	2,00	2,00	2,00	2,00	2,00	2,00	1,90	1,90	1,90	1,90	1,90	1,50	1,50	1,50	1,50	1,50	1,50	
T	120	100	120	100	120	100	120	100	100	100	100	120	80	80	80	80	80	
P	60	60	60	60	60	60	60	60	60	60	60	40	40	40	40	40	40	
E	3	3	3	3	3	3	3	3	3	3	3	2	2	2	2	2	2	
MEJORA S TUBO mm	3	3	3	3	3	3	3	3	3	3	3	2	2	2	2	2	2	
CIMENTACION cm	0,85	0,75	0,80	0,70	0,85	1,35	1,10	0,70	0,60	0,55	0,60	0,70	0,80	0,40	0,45	0,55	0,40	0,65
A	0,40	0,50	0,50	0,50	0,50	0,60	0,40	0,40	0,40	0,40	0,40	0,40	0,40	0,40	0,40	0,40	0,40	0,40
B	0,80	0,80	0,80	0,80	0,80	0,80	0,80	0,80	0,80	0,80	0,80	0,80	0,80	0,80	0,80	0,80	0,80	0,80
Z	0,80	0,80	0,80	0,80	0,80	0,80	0,80	0,80	0,80	0,80	0,80	0,80	0,80	0,80	0,80	0,80	0,80	0,80

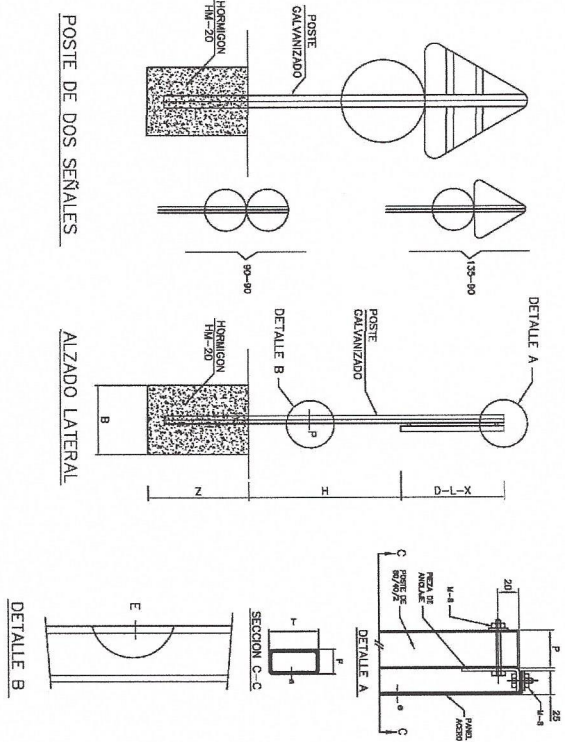
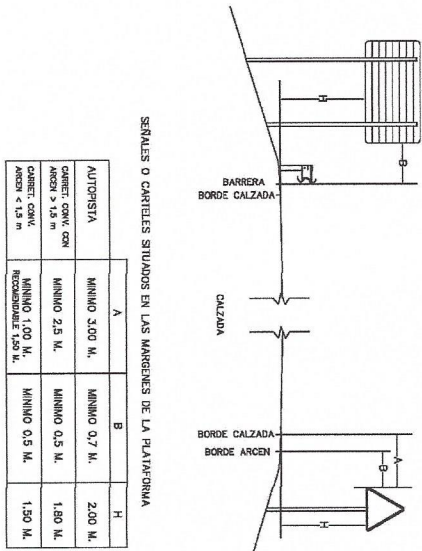

- NOTAS**
- 1 - TODOS LOS CARTELES DE LAS SEÑALES SON DE ALUMINIO GALVANIZADO
 - 2 - LAS CARACTERÍSTICAS DE LAS SEÑALES (COLOR, DIMENSIONES, ETC.) SECON LAS NORMAS EN-12740.
 - 3 - LAS SEÑALES INFORMATIVAS SE SITUAN DE TAL MODO QUE LA CURVA DEL TEXTO SE GIRE HACIA EL TUBO PORTADOR EN PLANTA EL PUNTO UN ANCHO DE 5-10 GRADOS CON LA NORMAL DEL LÍNEA.

AUTOR DEL PROYECTO:
EHEGARRA-ECURRA,
INGENIERO
2015

NOMBRE DEL PROYECTO:
MEJORA Y ENSANCHE DE TRAMO ENTRE LOS
PKK 0+100 Y 0+480 EN NA-7063 (EGULLIOR -
VALLE DE OLLIO)

DESIGNACIÓN DEL PLANO
DETALLES CONSTRUCTIVOS
-SEÑALIZACION VERTICAL -

ESC.: A-4
VARIAS
(ACOTADO)

PLANO 11/12

DATA: 21-11-14

HOJA 2 DE 02



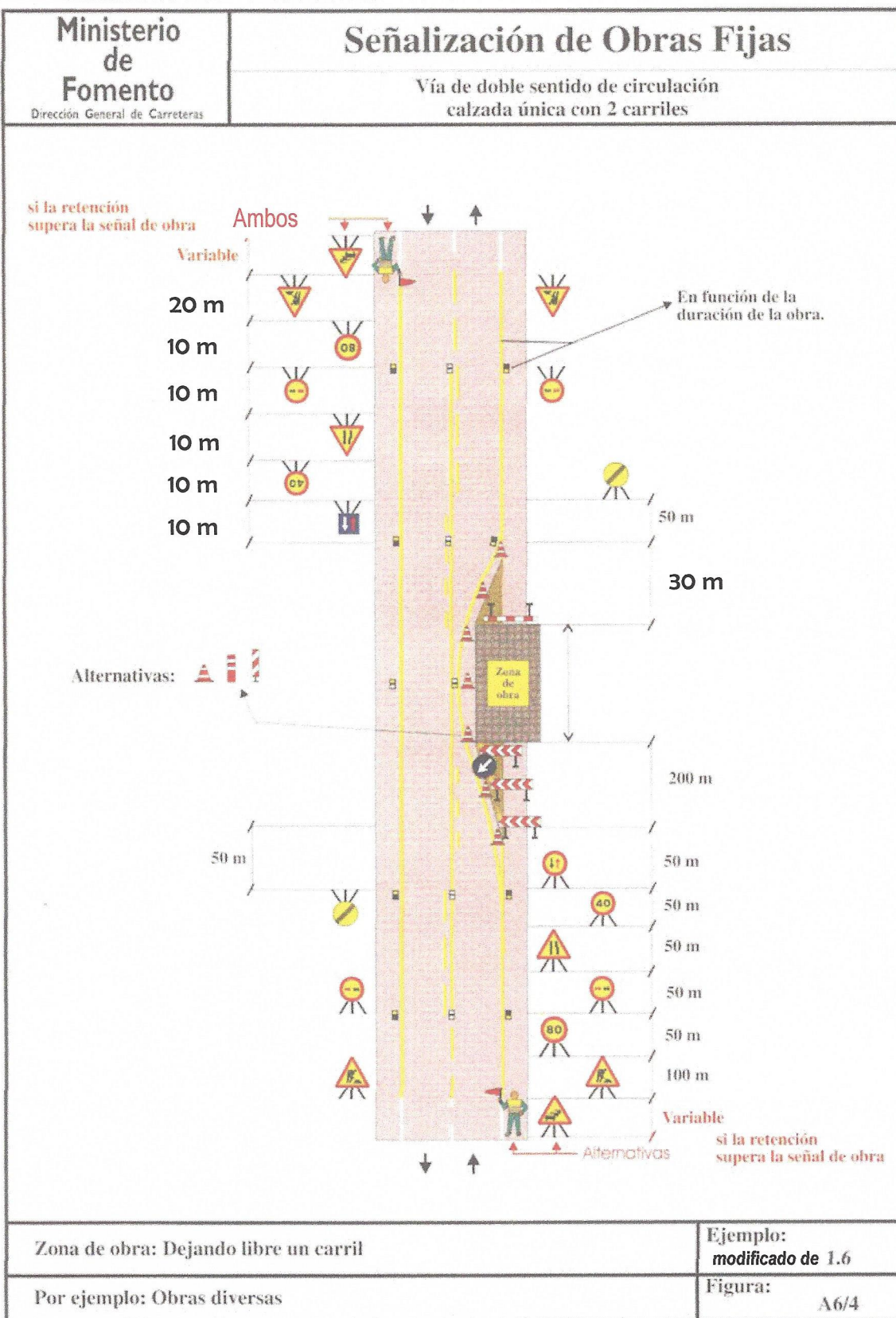

	<p>AUTOR DEL PROYECTO: ECHEGARAY EZCURRA, IÑIGO</p>	<p>NOMBRE DEL PROYECTO: MEJORA Y ENSANCHE DE TRAMO ENTRE LOS PPK 0+100 Y 0+480 EN NA-7063 (EGUILLOR – VALLE DE OLLO)</p>	<p>DESIGNACIÓN DEL PLANO SEÑALIZACIÓN DE OBRAS</p>
		<p>ESC.: A-4 S/S (ACOTADO)</p>	<p>HOJA 1 DE 01</p>
		<p>DATA: 21-11-14</p>	<p>PLANO 12/12</p>